



Bobcat®

COMPACT EXCAVATORS

E60



One Tough Animal™

E60 – SPECIFICATIONS

Weights

Operating weight with standard bucket, excluding operator	6025 kg
Additional weight for long dipperstick	115 kg
Ground pressure with standard dipperstick and rubber tracks	32.51 kPa

Engine

Make / model	Yanmar / 4TNV98-ESDB6
Fuel	Diesel
Number of cylinders	4
Displacement	3300 cm ³
Maximum power at 2200 RPM (DIN 6271)	37.3 kW
Maximum net torque at 1400 RPM	206.0 Nm

Performance

Digging force, standard dipperstick (ISO 6015)	26000 N
Digging force, long dipperstick (ISO 6015)	22600 N
Digging force, bucket (ISO 6015)	39900 N
Drawbar pull	51975 N
Travel speed, low range	2.1 km/h
Travel speed, high range	3.9 km/h

Hydraulic System

Pump type	One engine-driven tandem axial piston pump and two engine-driven gear pumps
Total pump capacity	144.10 L/min
Auxiliary flow	52.50 L/min
System relief pressure for auxiliary circuit 3	230.00 bar
System relief pressure for auxiliary circuit 2	210.00 bar
Auxiliary relief	230.0 bar

Slew System

Boom swing, left	70°
Boom swing, right	50°
Slew rate	9.6 RPM

Fluid Capacities

Cooling system	4.20 L
Engine lubrication plus oil filter	11.60 L
Fuel reservoir	78.00 L
Hydraulic system	100.00 L

Environmental

Noise level LpA(EU Directive 2000/14/EC)	77 dB(A)
Noise level LWA(EU Directive 2000/14/EC)	97 dB(A)

Standard Features

1980 mm dozer blade	Consoles with forwards/backwards adjustable displacement
400 mm steel tracks	TOPS/ROPS cab ¹
Engine/hydraulic monitor with shutdown	Boom load holding valve
Fingertip auxiliary hydraulic control	Harness for rotating beacon
Control console locks	Fully adjustable air conditioning
Hydraulic joystick controls	Overload warning device
Two-speed travel	Sun visor
Lockable storage compartment	Left rear view mirror
Horn	Electric refueling pump
Work lights	Auto idle
Retractable seat belt	Warranty: 12 months, 2000 hours (whichever occurs first)
Suspension seat with high back	

1. Tip Over Protective Structure (TOPS) – Meets requirements of ISO 12117

Working Range

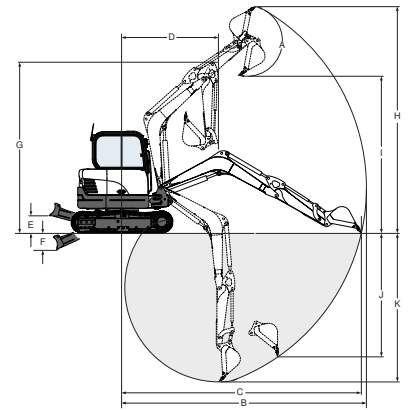

(A) 179°	(G) 4296.0 mm
(B) 6130.0 mm	(H) 5685.0 mm
(C) 6005.0 mm	(H*) 5853.0 mm
(C*) 6380.0 mm	(I) 3940.0 mm
(D) 2415.0 mm	(I*) 4125.0 mm
(D*) 2500.0 mm	(J) 3095.0 mm
(E) 435.0 mm	(K) 3725.0 mm
(F) 415.0 mm	(K*) 4145.0 mm

Dimensions

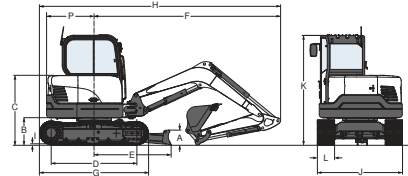

(A) 350.0 mm	(I) 14.0 mm
(B) 820.0 mm	(J) 1980.0 mm
(C) 1623.0 mm	(K) 2550.0 mm
(D) 1990.0 mm	(L) 400.0 mm
(E) 1805.0 mm	(M) 667.0 mm
(F) 4295.0 mm	(N) 818.0 mm
(G) 2550.0 mm	(O) 2415.0 mm
(H) 5565.0 mm	(P) 1102.0 mm
(H*) 5669.0 mm	(Q) 2180.0 mm

Options

Rubber tracks	Third auxiliary hydraulic line
2nd Auxiliary hydraulics	(Clamshell Piping)
	Long dipperstick



Bobcat входит в группу компаний Doosan.

Корпорация Doosan является мировым лидером в производстве строительной техники, энергетического оборудования, систем водоснабжения, двигателей и предоставлении инженерных решений заказчикам на протяжении более ста лет. Bobcat и логотип Bobcat являются зарегистрированными товарными знаками компании Bobcat Company в США и других странах. ©Bobcat Company, 2018. Все права защищены.



ЗАО ГЛАВНЫЙ ЭЛЕМЕНТ

ул. Липковская 9/5
220138 Минск
Тел./Факс.: +375 (17) 385-12-66
info@dst.by
www.dst.by



Bobcat®